

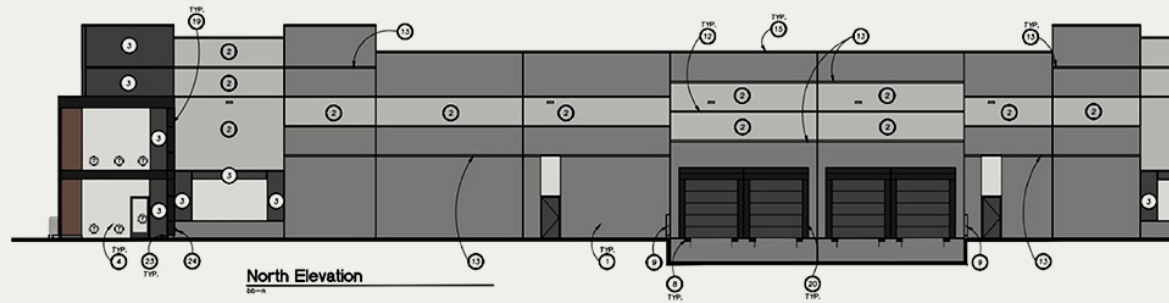

robert evans company
DEVELOPMENT | CONSTRUCTION

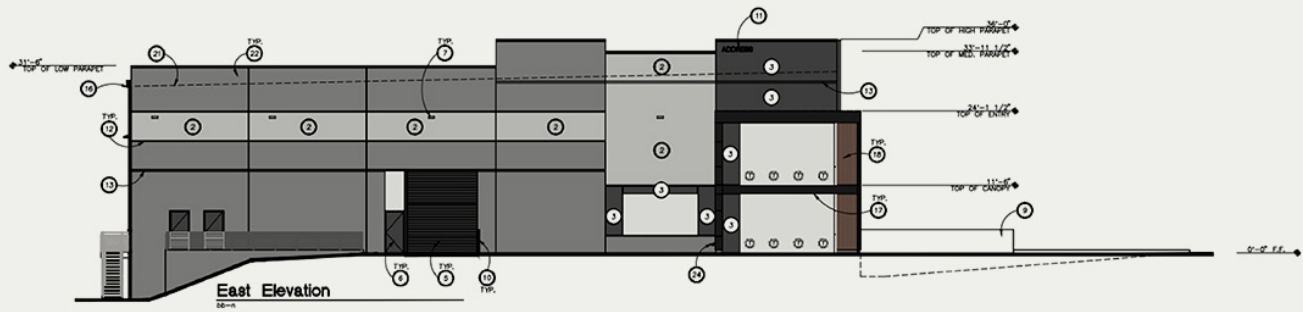

fast-track custom

Make it yours.

Learn more at robertevansco.com/fast-track-custom

Fast-Track Custom makes sense for small businesses and land owners.

Robert Evans Company created the Fast-Track Custom development model as a path toward a new building for the region's small business owners. We harness the power of alignment to create transparency, eliminate multiple fees, and accelerate the project timeline.

- **Flexibility:** Choose the financing route that works for you: purchase, lease to own, or long-term lease.
- **Customization:** Tailor the space to reflect your vision and support your operations.
- **Quality:** Work with a team that strives to build legacies we're as proud of as their owners.
- **Convenience:** Because we own the process start to finish, we are your single source of solutions.
- **Efficiency:** We have already taken care of the initial permitting phases, saving you 4–6 months.
- **Peace of Mind:** This endeavor can be daunting. Rely on our expertise to plan with confidence.

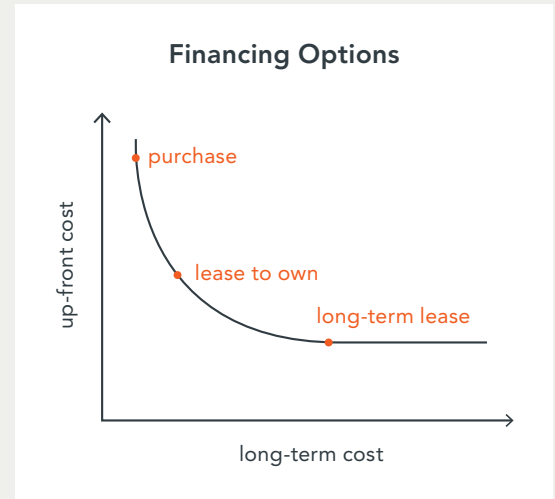

Our next Fast-Track Custom Project is located in Hillsboro, Oregon—and we're ready to break ground when you are.

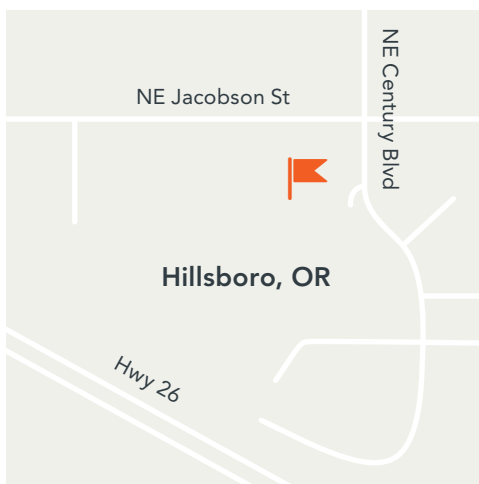

Customization Options:

- **Floor Plan:** added mezzanine space
- **Office:** size, heating and cooling zones, number of conference rooms and private offices
- **Warehouse:** # of loading docks, # of grade high doors, high pile storage, # of dock levelers, lighting types (LED)
- **Manufacturing:** tool connections, power demand, containment/dust control

Contact us at office@robertevansco.com to start the conversation.



robertevansco.com
503.648.7805